



# Hammerhead TL

## 24MP Outdoor Time Lapse and Construction Photography System



Photograph your project with the stunning clarity of a Canon EOS Digital Mirrorless camera

Mobile Broadband equipped and ready to capture, archive and upload anywhere in the United States

Powerful automated 7 day scheduler

IP68 rated all-weather enclosure

128GB+128GB redundant local storage

The Hammerhead TL is the perfect for tool for capturing mission critical time lapse footage. Utilizing a 24MP mirrorless camera, this system is ready to photograph, archive and upload from anywhere. The system

comes equipped with a cellular modem making it easy to tweak and configure any settings remotely as well as giving you critical operational alerts. The package is outdoor ready utilizing an impact resistant polycarbonate enclosure that is impervious to water penetration. All of this combined makes the Hammerhead TL system a complete package able to deliver time lapse photography from anywhere.

The EOS M50 from Canon is the newest mirrorless shooter compatible with our core technology. Sighting in at 24MP, it has the resolution necessary to produce time-lapse frames that are over 12x larger than 1080p HD video and over 3x larger than 4K(2160p) video. When combined with Canon optics, it is able to capture your project in amazing clarity and detail. When true photographic quality is necessary you can rely on the optical and digital quality that a professional Canon camera can provide.



### Canon EF-M 11-22mm Lens

- Horizontal Angle of View - 91° to 54°
- Vertical Angle of View - 68° to 37°
- Aperture - f/4.5-5.6 to f/22-32
- Construction - 12 elements in 9 groups
- Focus Motor - STM with remote focus capability

### Your Choice



### Canon EF-M 15-45mm Lens

- Horizontal Angle of View - 74° to 28°
- Vertical Angle of View - 53° to 19°
- Aperture - f/3.5-5.6 to f/22-36
- Construction - 10 elements in 9 groups
- Focus Motor - STM with remote focus capability

## Robust, Web Enabled, Time Lapse Photography Systems

TL Series are suitable for a wide range of applications, including construction site monitoring & documentation, timelapse for marketing purposes, scientific, and other documentary uses.

### Plug it in, call us, and we do the rest

Installation is easy as the camera comes web enabled out of the box. If you can find a place to put the camera simply power it up and call us and we can help you the rest of the way. Within just 15 minutes we can have your website up and running and available to view from your smartphone, tablet ,PC or Mac.

### Easy access to your image archive history

Our TL series offers cameras suitable for a range of documentation applications, including live construction site monitoring via our website. Authorized users can download the entire image archive via FTP at anytime or use the web based image viewers to browse the image archive, view timelapse movie playback, compare one image to another using easy overlay controls, email an image, and more.

### A Turnkey solution

Our cameras save installation time and costs since they are ready out of the box for mounting outdoors. The IP66 system has protection against dust, rain, snow and sunlight, and can operate in temperatures as low as -40 °C (-40 °F) when upgraded with our cold weather package. The cameras are powered by low voltage DC, which provides install flexibility and easy conversion to solar power. Standard mounts available include pedestal, wall and pole. Specialized mounts such as Non-Penetrating Roof Mounts are available for an additional surcharge.

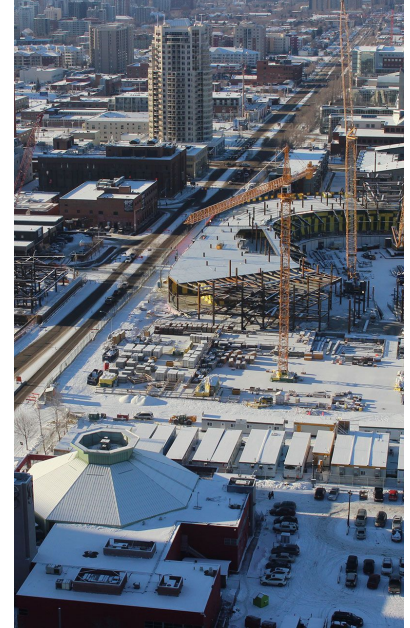

One or more cameras on  
AC or Solar Power

Upload



Erdman Server Platform

Browse

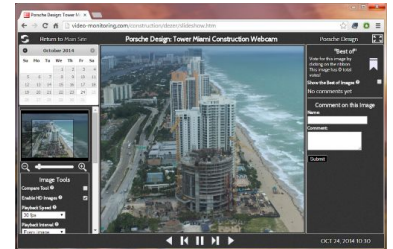

View online in Erdman's  
HTML5 Slideshow for  
desktop and mobile

### EVS Center protection to watch over the entire shoot from beginning to end

The camera system continually communicates with our EVS Central Alert system to keep your system running reliably. When an issue arises that requires outside assistance the camera station sends an alert to the EVS Center which is then re-broadcast in the form of smartphone text messages or emails to designated persons on a contact list.

### A mature system developed over 25 years and thousands of projects

Our core technology is the result of over 25 years experience deploying timelapse systems in rough outdoor conditions across the globe. With a built in solar mode of operation and it's integrated cell modem the device comes web enabled out of the box for easy installation on almost any project site.

Configure your system in our  
[online quotation form!](#)

Get [more information](#) about  
the Hammerhead TL system.

[Find out more](#) about Erdman  
Video Systems, where we've  
been and where we are  
headed

## Technical Specifications - Hammerhead TL

Canon EOS M50 Spec	
Image sensor	22.3mm x 14.9mm APS-C
Image format	24.1MP resolution 6000px x 4000px picture size 3:2 image ratio JPEG or JPEG+RAW
Camera settings	ISO 100 to 25600, 6 White balance settings, TTL maximum aperture metering with 384-zone metering sensor Evaluative metering, ±5 stops exp compensation
Camera features	EF-M lens mount, DIGIC 8 Image processor

NanoTL Embedded Module Specs	
Processor	CPU: 64 bit Intel Atom E3825 Frequency: 1.33GHz Cores: 2 Threads per core: 2
Memory	Type: DDR3L Speed: 1066MHz Capacity: 4GB
Hard Drive	OS: 8GB SSD mSATA -40°C to +85°C Images: 2x 128GB removable USB flash storage <b>Upgrades:</b> 2x 258GB removable USB flash storage
OS	Microsoft Windows Embedded Standard 8
Micro-controller	Erdman Proprietary Watchdog Firmware
PC Ports	1x Gigabit Ethernet 3x USB 2.0 1x USB 3.0 1x VGA 2x RS232
Input	12-30v DC 7.08W typical power consumption
Output	3 switched outputs: Input V fused at 5A Camera: 8v fused at 3A PC: 12v fused at 3A
Environmental	Temp spec for inside enclosure: Regular: 0°C to +60°C (+32°F to +140°F) <b>Cold weather upgrade:</b> -40°C to +85°C (-40°F to 185°F)
Dimensions	2.5" Pico ITX (100 x 72mm)

Overall System Spec	
Housing	Dim: 20.8"(L) x 7.5"(W) x 5.9"(H) Material: UV stable polycarbonate Weatherproofing: IP66 rated Color: White <b>Upgrades:</b> Cold weather package adds a heater/blower and foam insulation (see pg4 for drawing)
Mount	Aluminum Pole, Wall, or Pedestal with 360° manual swivel adjustment <b>Upgrades:</b> Heavy duty upgrade available, non-penetrating roof mounts available (see pg4&5 for drawing)
Power Input	100-240v AC input @ 0.25A 3 prong plug with 8ft cord <b>Upgrades:</b> Solar power kits available (system can be powered by pure DC input)
Cellular	Verizon 3g/4g internal modem <b>Upgrades:</b> Add internal antenna or go external with a full industrial grade IP67 modem solution

VM95 Software Spec					
Programming	80 programmable "scenes" Programmable scenes include: image capture, uploading, image manipulation, compositing, sensor sampling, rebooting, sleeping	Image Capture Settings	Resolution, ISO, Exposure, Aperture, Exp. Compensation, White Balance, Quality, JPEG compression	Solar Mode	System can go into low power sleep state for operation utilizing batteries and/or solar. Sleep intervals from 3 min to 1 day.
Sample Interval	1 sec to 1 week Day of week selectable Start and stop time selectable "on-the-minute" capable	Image manipulation	Timestamp, resize, rotate, crop, brightness, contrast, thumbnail creation	Archiving	Set up to 4 separate archive drives System manage archive size will keep drives from filling up.

# Drawings and Dimensions

## Camera housing

## Housing Certifications

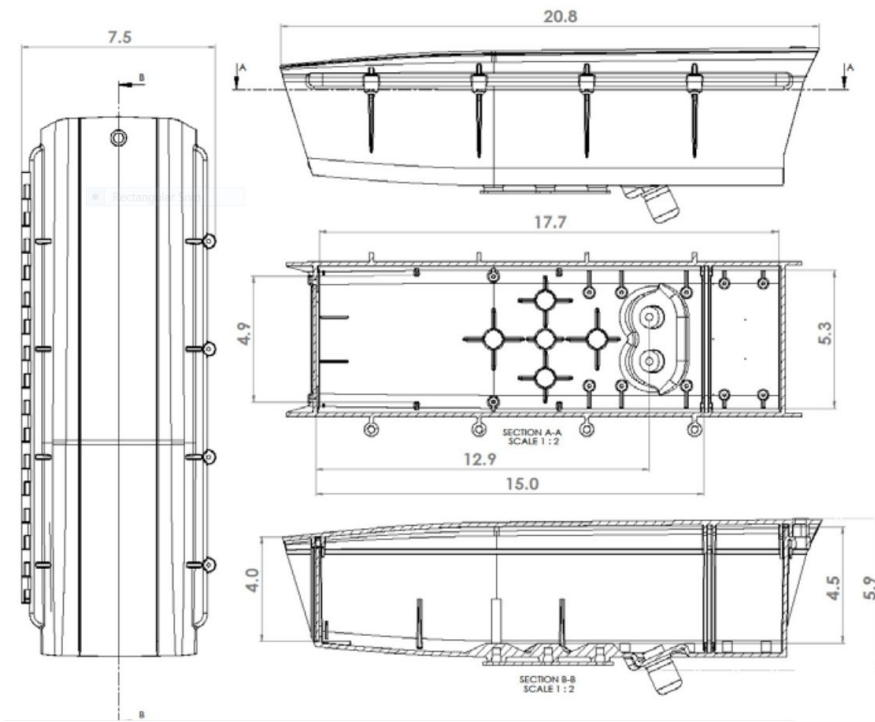

Standard camera pole mount

Standard wall mount

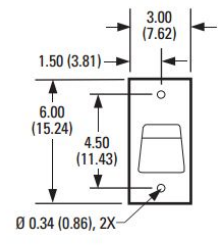
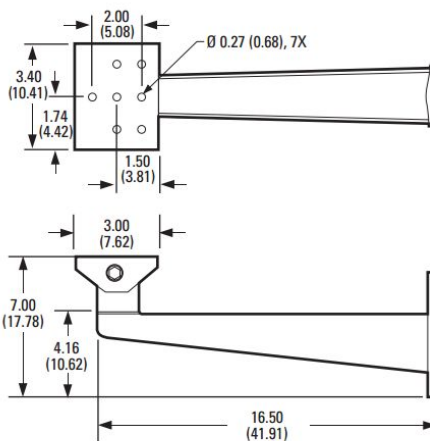
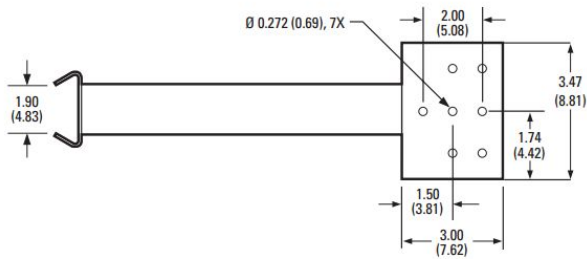

NOTE: VALUES IN PARENTHESES ARE CENTIMETERS; ALL OTHERS ARE INCHES.

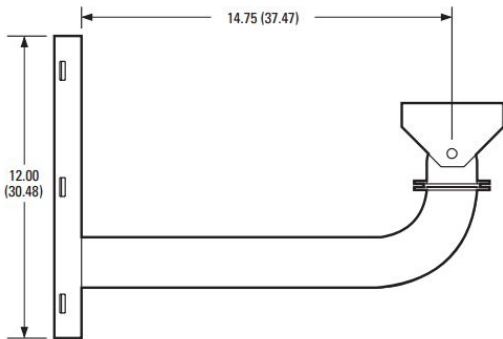

EM2000

### Heavy Duty Mount Upgrade

Adjustable Head  
- Used with Pole, Wall and Pedestal

Wall mount  
- Used with Pole and Wall

Pole Adaptor  
- Used with Pole only

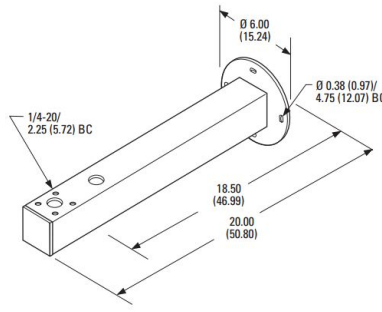
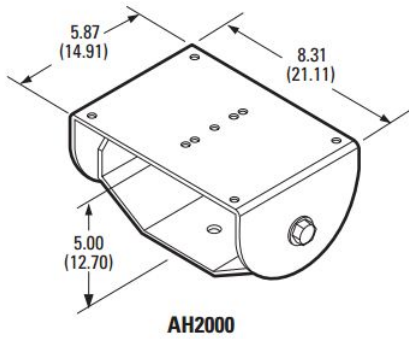

NOTE: VALUES IN PARENTHESES ARE CENTIMETERS; ALL OTHERS ARE INCHES.

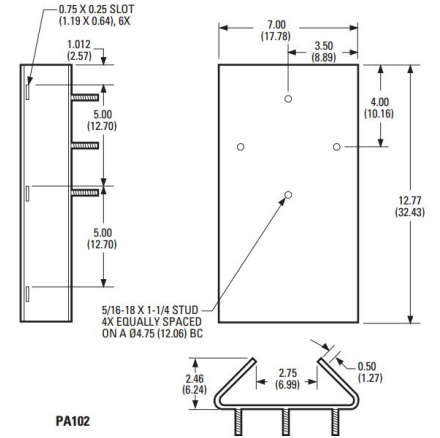

### Pedestal Mounts

Regular Pedestal

Heavy Duty Pedestal

